



REMOTE MONITORING AND CONTROL OF CATHODIC PROTECTION

Commission 2, Working Group A

June 15, 2015

Disclaimer

This CEOCOR publication or information has been prepared in good faith by volunteers, however no representation, warranty, assurance or undertaking (express or implied) is or will be made, and no responsibility or liability whatever is or will be accepted by CEOCOR AISBL and/or by its members, board members, management and volunteer contributors in relation to the adequacy, accuracy, completeness or reasonableness of this publication or information. All and any such responsibility and liability is expressly disclaimed. This publication is provided as is and is to be used at the recipient's or users own judgement, evaluation and risk. The recipient is advised to consider seeking professional guidance with respect to this publication and its use.

© CEOCOR AISBL

Table of Content

Foreword	3
1. Scope	3
2. General	3
3. Philosophy of a CP remote monitoring system	4
4. Terms, Definitions and Symbols	5
4.1 General	5
4.2 Terms and definitions	5
4.3 Symbols	6
5. Benefits of remote monitoring and control	6
6. Levels of remote monitoring	7
6.1 General	7
6.2 Remote monitoring of functional operation.....	7
6.3 Remote monitoring of CP efficacy	8
6.4 Remote control	8
7. Frequency of on-site routine checks of remotely monitored CP equipment	9
8. Design of a remote monitoring and control system	9
8.1 General	9
8.2 Design of a monitoring system	10
8.3 Processing of monitored data	10
8.4 External interference parameters	11
8.5 Remote monitoring equipment: Technical requirements	11
9. Commissioning of remote monitoring installation	13
10. Operation of remote monitoring installation	14
List of Annexes	15
Literature, references	15
Annex 1	16
Annex 2	19

Foreword

This document has been prepared by **CeoCor** working group members and provides a common agreement on a “best practice” for Remote Monitoring and Control of cathodic protection systems for buried or immersed structures. This has been prepared based on what is known of the technologies at the time the document was formed.

This document has been prepared with the help and best knowledge of **CeoCor** Commission 2 members. A complete list of participating members is appended to this document.

1. Scope

The aim of the document is to merge and describe fundamental and important recommendations, specifications and experiences in the field of Remote Monitoring and Control of cathodically protected structures.

For the purpose of this document, protected structures are represented by buried or immersed steel pipes or tanks that are equipped with a cathodic protection (CP) system. The minimum requirements for CP of such structures are described in EN standard [1].

This document does not detail the requirements for cathodic protection; its intent is to provide uniform terminology to describe and define remote monitoring.

2. General

Cathodic protection remote monitoring and control systems typically comprises electric measuring sensors installed at CP test posts and/or CP equipment such as transformer rectifiers that facilitate the transmission of data related to the operation of the CP from in-situ technology to a monitoring centre via a transmission path. The general principle of a system is drawn in Figure 1.

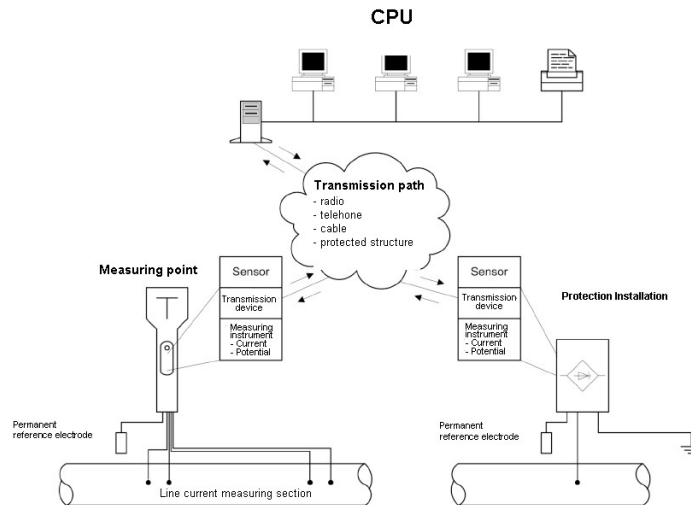

Figure 1 – General scheme of remote monitoring CP system

3. Philosophy of a CP remote monitoring system

CP measurements have to be carried out at specified periodicities to support the processes necessary to prove or validate the effectiveness of a CP system or simply to prove its functionality. With the use of remote monitoring, it is the pipeline operator's responsibility to define an adequate periodicity and the purpose of remote monitoring.

Examples for the application of remote monitoring systems are:

- Impressed current stations,
- Galvanic anodes stations,
- Drainage stations,
- Ac mitigation stations,
- Bond stations between pipelines or structures,
- Test posts.

When a remote monitoring system is installed, it can adopt part or all of the advantages detailed in § "5. Benefits of remote monitoring and control". In consideration of the costs to use and to optimise the installation and use of a CP remote monitoring system, it is the pipeline operator's responsibility to define:

- which CP equipment to remote monitor or control,
- which levels of remote monitoring (see § "6. Levels of remote monitoring") are required.

It is not necessary to remotely monitor or control all CP equipments. In addition, it is possible to combine different levels of remote monitoring. This offers opportunities to

pipeline operators to create a specific CP remote monitoring system in accordance with their own pipeline network requirements.

Measurements made by the CP remote monitoring system and measurements carried out in the field by CP operators shall prove the functionality and effectiveness of the CP system.

4. Terms, Definitions and Symbols

4.1 General

All terms and definitions related to cathodic protection are used according to EN standards [1, 2, 3]. For the purpose of the document, the following additional terms, definitions and symbols are used.

4.2 Terms and definitions

Processing Unit (PU) – set of electronic devices used to collect from RMU, to store, to process and to distribute the monitored data and signals to the user. In case of control system, the PU controls target CP equipment via the RMU.

Reference Value – measured characteristic value (e.g. potential, current, resistance, etc.) related to CP operation on a given structure, taken in a period when the CP equipment or CP system is operating without any system failure and the whole structure is effectively protected. In conditions that the structure is not influenced by stray current, a reference value could be represented by an instantaneous value. In conditions where the structure is influenced by stray current, a reference value could be represented by minimum, maximum and average value processed in a given period.

Remote Monitoring System – system that has the capability to verify the functionality and/or effectiveness of CP system.

Remote Control System - system that has the capability to verify the functionality or/and effectiveness of a CP system and remotely control the operation of the cathodic protection system.

Remote Monitoring Unit (RMU) - electronic device that has the capability to monitor and/or control selected CP equipment or a part thereof from a remote location.

Note: An RMU is usually installed in the field to the CP equipment that can be remotely monitored and/or controlled.

4.3 Symbols

I_P – protective current

I_d – drained current

I_b – current across a bond

I_{dc} – current across a dc decoupling unit (usually equal to zero)

I_{ac} – ac discharge current

I_C – coupon polarised current

$I_{C\ ac}$ – ac current through a coupon

E_{ON} – on potential

E_{OFF} – off potential

U_{OUT} – output voltage of a rectifier

U_{S-R} – voltage of the structure with respect to the power rail of traction system

U_{ac} – ac voltage over structure to soil

5. Benefits of remote monitoring and control

Depending on the implementation and operation and maintenance requirements of a CP system, the utilisation of CP remote monitoring or control can bring an operator the following benefits:

- continuously streamed or immediately available on demand information, that the CP equipment or system is in operation.
- notification of fundamental failures of CP equipment or impairment of CP efficacy;
- reduced time delay between failure occurrence and failure notification;
- remotely monitor the effectiveness of a CP system along an entire structure or a selected part of it;
- enhanced knowledge regarding the performance of a CP system over a long period of time;
- remote control and modification of selected CP operation parameters;
- reduction or replacement of periodic routine in field checks and/or measurements;
- long term reduction in operating costs;
- assistance for the implementation and optimisation of selected test post monitoring programs.

The technical requirements, the condition and the configuration of protected structures and operator requirements will determine which benefits would best be achieved by implementing a CP remote monitoring or control system.

6. Levels of remote monitoring

6.1 General

When compared to routine periodic checks and controls of CP systems as defined by EN standards [1], remote monitoring systems can be divided into the levels in Table 1:

	Levels of Remote Monitoring
1.	Monitoring of functional operation
2.	Monitoring of CP efficacy
3.	Remote control

Table 1 – Level of Remote monitoring system

Examples of options for remote monitoring systems are shown in **Annex 1**.

5.2 Remote monitoring of functional operation

Systems belonging to this category should be able to detect principal failure of monitored CP equipment by means of monitoring key operational parameters. This level of CP monitoring usually implies the collecting and/or measurement and transmission of data that provides an operator with sufficient information that selected CP equipment functions within a range determined by an operator that confirms its functionality.

The selection of a parameter to be monitored requires a suitable interface of the CP equipment to the remote monitoring equipment. It must be selected in a way to provide reliable information regarding the operational status of the equipment (for example: failure of ac supply from main feeder cable to the dc power source is a reliable method to confirm that a CP station is not in operation. On the other hand, the mere presence of ac voltage in the electric main feeder does not ensure that a protective current is flowing to the protected structure).

Monitoring of functional operation can be provided by following signals that indicate deflection from the pre-set threshold reference value and/or by measuring selected parameters.

Failure should be notified by interface of an RMU to the PU with some reasonable but minimal time delay. The maximum time delay should be defined by the operator.

6.3 Remote monitoring of CP efficacy

This level identifies the impairment in the efficacy of a CP system on structures. Parameters to be measured and monitored should provide an operator with reliable information about CP effectiveness of the structure. Occurrence of any failure that reduces CP performance of a structure, or its part, should be covered by the system. A suitable monitoring regime for CP efficacy should reflect the structure design, build parameters, environment, interference and operating conditions.

The measurements to verify CP efficacy by remote monitoring should record and transmit all the necessary data required for this purpose as identified in the appropriate standards.

The data obtained by remote monitoring systems should be compared to the key reference values such as protection criteria (and be given over a range of predetermined acceptable values).

Impairments to the performance of a CP system should be notified by interface of an RMU to the PU with some reasonable time delay. The maximum time delay should be defined by the operator.

6.4 Remote control

Remote control systems correspond to the monitoring systems described in 6.2 or 6.3 above but which also allow to remotely change the operational status of CP equipment or the parameters to which they operate.

When a monitored CP parameter is changed by remote control, the system must be designed in a way to give an operator the relevant information that determines the impact of any change. The response time of a system to update parameters that have been directed by remote control should be minimal.

When synchronised operation of several RMU's is required, the synchronisation precision shall be appropriate to deliver the necessary accuracy of measurement at all RMU's over a planned campaign of measurement. The synchronisation precision should either be regularly re-established and the synchronisation deviation should be periodically checked to confirm that it remains within an acceptable range.

7. Frequency of on-site routine checks of remotely monitored CP equipment

Applying remote monitoring systems that enable the monitoring (and control) of CP equipment according to [1], allows the frequency of functional checks made by CP operators in the field to be modified as Table 2:

On site routine check	Without remote monitoring	With remote monitoring ³
Permanent (installed, in situ, stationary) reference electrode	Once a year or more frequently (at selected test post)	Subject to proven electrode stability and/or remote validation (at RMUs test post)
Galvanic anode	Once a year or more frequently ¹	Every 3 years
Impressed current station	Every 3 months or more frequently ¹	Every 3 years
Drainages	Every month or more frequently ²	Every 3 years
Connections to foreign structures	Once a year or more frequently ¹	Every 3 years
Dc decoupling devices and earthing systems	Once a year or more frequently ¹	Every 3 years
Selected test post	Once a year	Variable depending on local practice

¹ if required by operational conditions

² if stray current is severe

³ subject to data being assessed as competent and indicating adequate protection

Table 2 – Frequency for on-site checks

Periodical checks and/or maintenance inspection and verification frequency of RMU and the associated sensors should be defined by the operator.

8. Design of a remote monitoring and control system

8.1 General

The following main aspects must be considered, when designing an application for CP remote monitoring and control:

- level of remote monitoring to be achieved as defined in 6.2 – 6.4,
- configuration of protected structure,
- ac and/or dc interferences that influence structure,
- site selection and condition,
- technical feasibility,
- operational costs,
- contractual obligations,
- legal aspects.

8.2 Design of a monitoring system

Providing monitoring of the functional operation of CP equipment usually represents the first step in a remote monitoring application. Remote monitoring of functional operation usually supposes to provide the following CP equipment with remote monitoring unit interfaces:

- galvanic anode;
- impress current station;
- electrical polarised drainage station;
- electrical bond between different structures;
- earthing systems (for draining ac or dc overvoltage arresters, etc.).

An example of which parameters can be selected to detect an occurrence of CP equipment failure is described in **Annex 2**.

Before installing remote monitoring units to monitor functional operation, the installed CP equipment should be inspected to confirm correct installation and performance. Reference values of monitored parameters should be defined by competent CP persons [9]. This can be undertaken during commissioning of a new CP installation or by ad hoc measurement, for CP equipment in continuous operation.

8.3 Processing of monitored data

Sampling frequencies for measured data reading shall be determined by the operator according to the conditions and characteristics of the structure.

When monitoring a structure that is not influenced by external dc or ac interference, it is sufficient to take at least one reading per day and to transmit it to the PU. The time of the day for data may be selected by the operator.

If the data recorded by the RMU are not in the appropriate parameters or range, remote monitoring of functional operation should initiate a spontaneous alarm signal to the CPU with minimal time delay. The maximum time delay should be defined by the operator.

Results of "on demand" measurements provided via remote monitoring system should be available in a form of individual readings from all selected parameters and during the whole measured period and/or as statistic data only e.g. maximum, minimum, standard deviation, average etc.

8.4 External interference parameters

Structures affected by dc and/or ac interference require more detailed consideration when applying CP remote monitoring system, due to the more extensive and complex range of representative test station data to be recorded by the local RMU.

The measurement range of individual RMU channels should correspond to an anticipated range of measured values and include adequate contingency.

In case of dc and/or ac interference, remote monitoring systems of CP effectiveness should allow a range of sampling times, periods of measurement, numerous CP equipment and operating parameters to be measured simultaneously.

In the presence of dc and ac interference, dc measuring channels should be provided with appropriate ac filters (attenuation min. 60 dB) to avoid inaccuracy of dc measurements.

8.5 Remote monitoring equipment: Technical requirements

The following technical requirements are the minimum that should be fulfilled by RMU and associated equipment when used for remote monitoring of CP systems.

Remote monitoring instruments should be developed with appropriate auto-recalibration/auto-verification systems, with self-diagnostic capabilities, in order to provide accurate notification when a fault occurs.

The stability of permanent reference electrodes needs to be monitored by appropriate measurements. This may include the use of several electrodes in the same location or comparison of the various electrodes along the pipeline in absence of IR-drops.

A periodic re-check of the commissioning calibration parameters should be automatically performed. In case of deviation (outside the instrument accuracy) a notification alert should be activated.

Measured and collected data shall be recorded and stored with the true actual polarity.

Input impedance of potential measurement instrument shall not be less than 10 M Ω .

In the case of E_{ON} measurements, recommended measuring ranges are as follows:

- ± 3 V (for structures not affected by stray currents);

- ± 30 V (for structures affected by stray currents).

In absence of dc stray currents, measurements of E_{OFF} potentials directly taken on the pipeline shall be recorded only when accurate switching synchronisation of power sources is established and proven. In any case, to avoid errors caused by discharge or equalizing currents, the appropriate potential measurement technique (e.g. coupon off potential) should be used and the measurement frequency and measurement start time should be variable and programmable.

Voltage measuring range may vary from 0V to 100 V (dc and/or ac) depending on condition of installation. In the case of pipe-to-rail dc voltage measurement both positive and negative polarity should be recordable.

A.c monitored parameters should be indicated as effective (RMS) values. Ac voltage range should be able to measure a presence of ac voltage within 16 2/3 – 100 Hz frequency range.

Current measurement is recorded as a voltage drop measurement across a shunt with a defined accuracy for nominal drained current. The resistance of the shunt should be selected at the minimum possible value, in order not to affect the measured current value. In the case of a shunt applied in a relative high current load circuit, the shunt should be selected in regard to possible over-heating. Deviation from rated resistance of a shunt should not exceed 1%.

Accuracy of measurements should be better than:

- 1 % of measured range for voltage measurements;
- 1 % of measured range for potential or current measurements.

RMU and associated equipment should be suitable for the climate and other environmental conditions associated with their installation. Detailed specifications (e.g. min. and max. ambient temperature, Ingress Protection rate IP etc.) should be specified by the operator.

RMU and associated cable terminals should be designed in such a manner as to be able to connect in parallel to external measuring equipment by an operator without excessive remedial works or risk of damage to either the RMU or the CP equipment.

RMU should be able to withstand such level of overvoltage and/or overload that may be expected at the location where it is installed. Surge and overvoltage protection may be installed within the CP equipment or individually for each RMU.

RMU can be powered by electricity taken from:

- ac power supply system;
- dc generating sources (e.g., photovoltaic, wind power, etc.);
- batteries;
- a combination of the above systems.

The power requirements are determined from the expected utilization of the RMU and depend on:

- measurement sampling rate (e.g., every second, every minute, once a day, etc.);
- frequency of data transmission (e.g., every day, every week, etc.);
- amount of data to be transmitted;
- connection operating status (on-line or off-line).

If the RMU is powered by batteries only, the battery life should be known to the user and the manufacturer and should be based on the proposed measurement and reporting frequencies.

9. Commissioning of remote monitoring installation

When commissioning the remote monitoring system, the values transmitted by the RMU shall be compared to and be of the same value as the values measured with calibrated instrumentation on site in the same measuring circuit. Such measurements may include:

- galvanic anode: I_p protective current forced by anode, E_{ON} , E_{OFF} ;
- impressed current station: I_p protective current, output voltage (ac and dc) of the dc source, E_{ON} , E_{OFF} ;
- polarized drainage station: I_d drained current, U_{S-R} structure to rail voltage, E_{ON} , E_{OFF} ;
- bond to other/foreign structure: I_d drained current, E_{ON} , E_{OFF} ;
- isolating joint: E_{ON} , E_{OFF} ;
- dc decoupling or ac discharge unit: E_{ON} , U_{ac} , I_{ac} ;
- test stations: E_{ON} , E_{OFF} ;
- coupons: I_{dc} and/or I_{ac} , E_{ON} , E_{OFF} .

Examples of parameters that can be selected to identify CP equipment failure and/or monitor (and control where required) CP efficacy of a structure are provided in **Annex 2**.

The installation of a sensor and RMU at each particular CP component should be stated by a protocol that describes all the technical parameters of the installed instruments, initial values of monitored parameters, the date of installation and any specific data required by the CP operator.

10. Operation of remote monitoring installation

The responsibilities for reviewing, analysing and reporting of the collected data shall be clearly defined. The persons responsible shall be competent in accordance with EN 15257.

Every instruction for a change in the CP operating parameters or operational status of CP equipment on-site should be clearly recorded along with the time of the change and the authorising person.

Acquired data should be regularly backed-up according to the requirements of operator of protected structure.

Accuracy of measuring sensors and instruments should be periodically verified according to relevant national and/or international standards and requirements of CP operator.

When a remote monitoring system indicates faulty operation of CP equipment and/or impairment of CP efficacy, the response time for sending a maintenance team on site to fix the problem will depend on the severity of the fault indicated. In general, unfixed faults and/or impairments of a CP system are potentially of higher risk to a structure influenced by stray currents than those which are not.

List of Annexes

1. Annex 1 – Examples of remote monitoring applications
2. Annex 2 – Table of parameters required for monitoring

Literature, references

1. EN 12954; Cathodic protection of buried or immersed metallic structures – General principles and application for pipelines.
2. EN 13509; Cathodic protection measurement techniques.
3. EN 50162; Protection against corrosion by stray current from direct current systems.
4. EN 15280; Evaluation of AC corrosion likelihood of buried pipelines – Application to cathodically protected pipelines
5. UNI 10950; Cathodic protection of buried metallic structures – Remote control of cathodic protection systems (English translation).
6. Technical Rule GW 10 Code of Practice; Cathodic protection of buried storage tanks and steel pipes – Commissioning and Monitoring (English translation).
7. Technical Rule GW 16 Code of Practice; Cathodic protection of buried storage tanks and steel pipes – Remote Monitoring (English translation).
8. Recommendation CEFRA COR - PCRA n°009; Telemetry systems for cathodic protection equipment of underground metal pipelines.
9. ISO/DIS 15257; Cathodic protection - Competence levels of cathodic protection persons - Basis for certification scheme.

Examples of remote monitoring applications

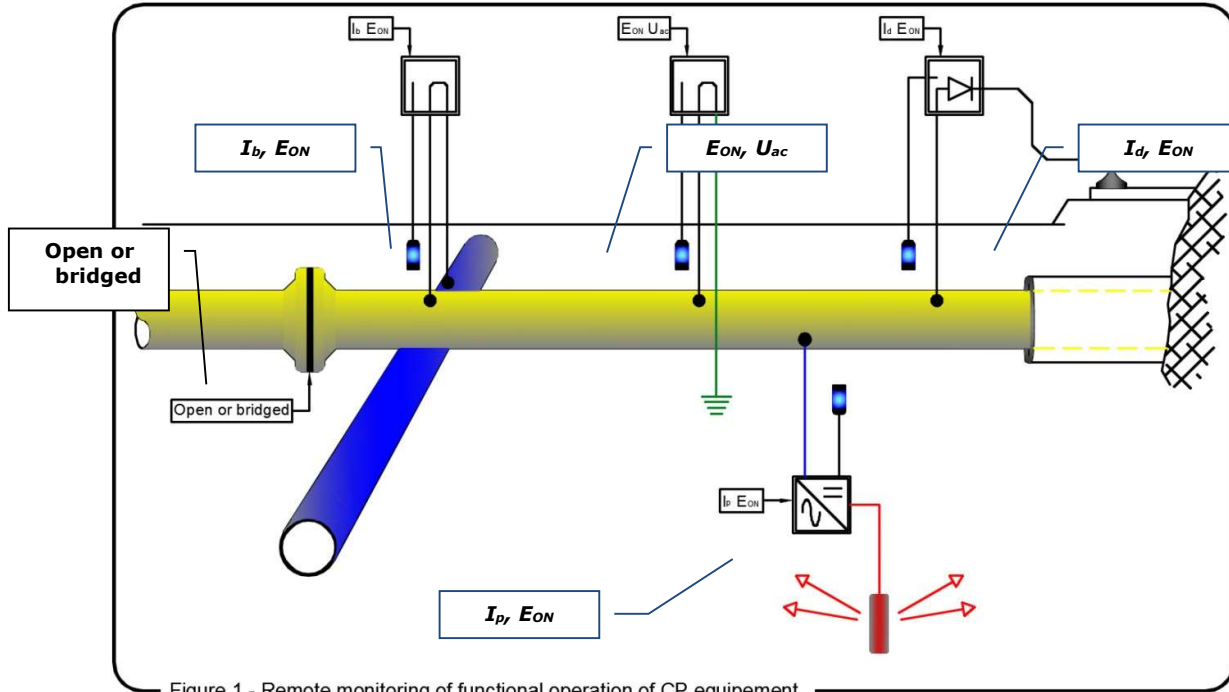

Figure 1 - Remote monitoring of functional operation of CP equipment

Figure 1 – Remote monitoring of functional operation of CP equipment

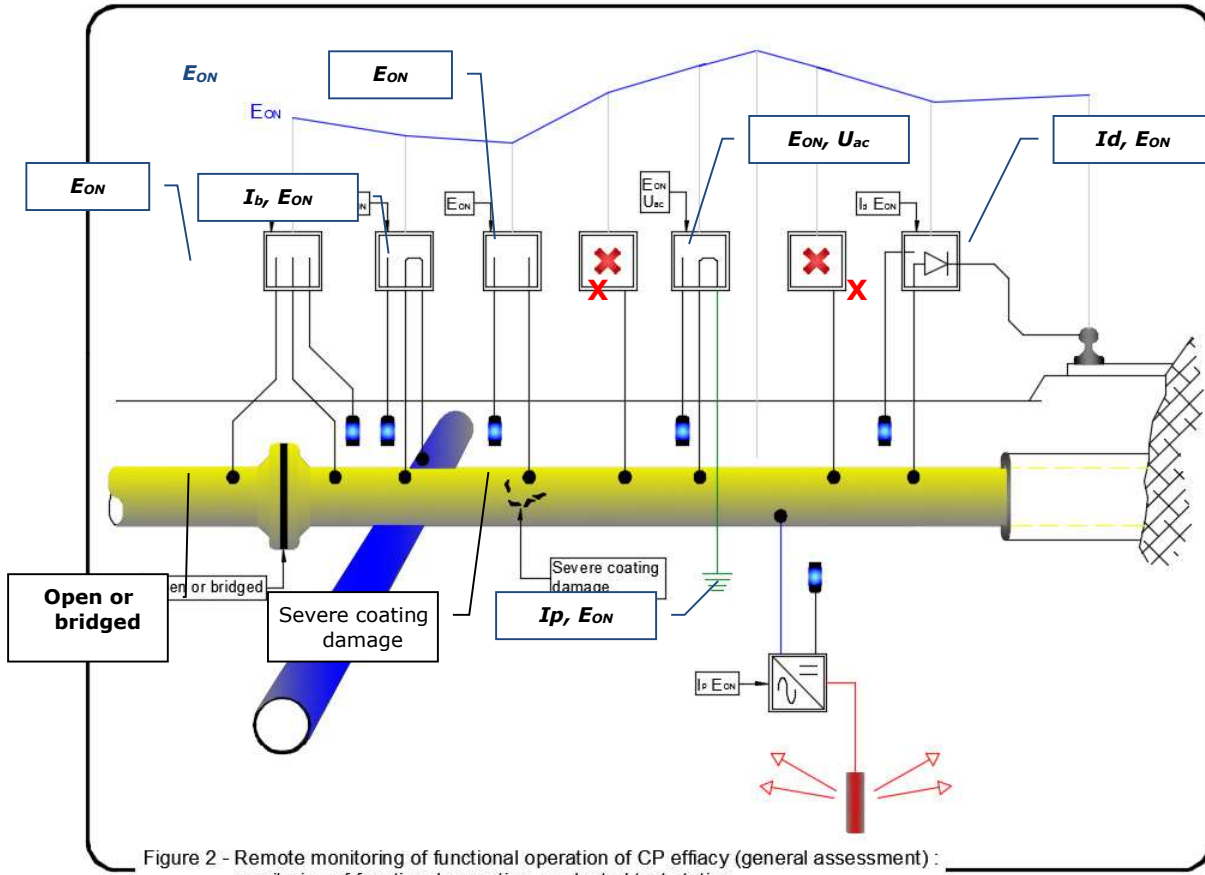

Figure 2 – Remote monitoring of CP efficacy (general assessment): monitoring of functional operation + selected test stations

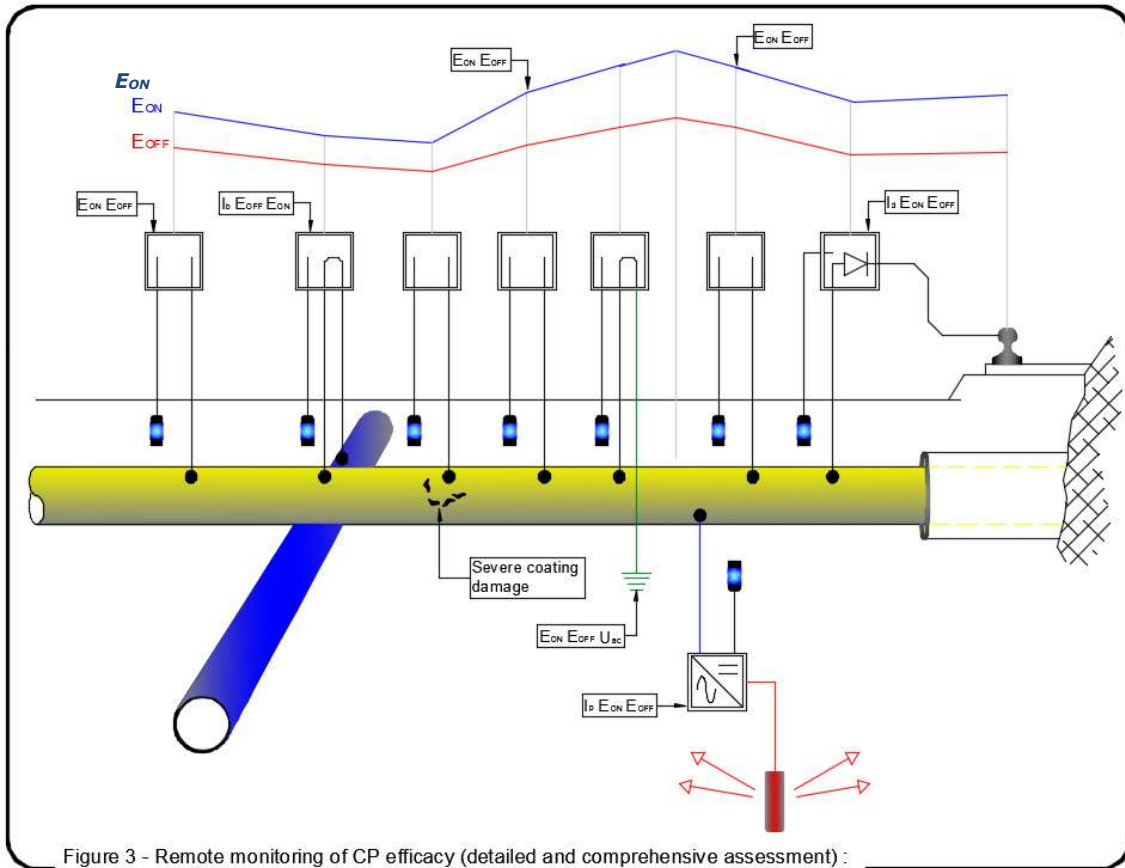

Figure 3 - Remote monitoring of CP efficacy (detailed and comprehensive assessment) : monitoring of functional operation + all test stations

Figure 3 – Remote monitoring of CP efficacy (detailed and comprehensive assessment): monitoring of functional operation + all test stations

Annex 2

List of parameters to be monitored and/or controlled

Unit/Equipment	Monitoring		Remote Control ³	Additional Possible Parameters
	Functional Operation ¹	CP Efficacy		
Galvanic anode	I_p, E_{ON}	I_p, E_{ON}, E_{OFF}	-	-
Impress current station	I_p, E_{ON}	I_p, E_{ON}, E_{OFF}	- I_p , - E_{ON} , - turn on/off, - cyclic switching mode	- open/close door, - supply ac voltage, - U_{out} - status of surge protection devices, - U_{ac} .
Drainage	I_d, E_{ON}, U_{S-R}	$I_d, E_{ON}, U_{S-R}, E_{OFF}$	-	- open/close door, - status of surge protection devices
Bond to other structure	I_b, E_{ON}	I_b, E_{ON}, E_{OFF}	- turn on/off,	-
DC decoupling unit or AC discharge unit	E_{ON}, U_{ac}	E_{ON}, E_{OFF}, U_{ac}	-	- $I_{d,c}, I_{ac}$
Test station	E_{ON}, I_c	E_{ON}, E_{OFF}, I_c	-	- corrosion rate, - U_{ac} , - $I_{c,ac}$.

¹ Monitoring of functional operation can be achieved by monitoring and transmitting the signal, when the monitored parameter has moved from a pre-set threshold or bandwidth or by measuring and transmitting selected value(s) of a parameter.

² According to EN 12954 for detailed and comprehensive assessment of CP effectiveness E_{OFF} potential should be measured and monitored.

³ Required parameters can be set by Remote Control System.