

CEOCOR

**MALMO Sweden Hilton Hotel
1st June – 3rd June, 2005**

SECTOR A - PAPER N. 3

**Alternating current corrosion of buried and cathodically protected steel
exposed to varying a.c. voltages -
And a new model for understanding of a.c. corrosion.**

FR

**Corrosion CA de l'acier, enterré et protégé cathodiquement, et exposé à
des tensions alternatives variables - Et nouveau modèle de compréhension
de la corrosion CA**

D

**Wechselstromkorrosion von Erdverlegten und kathodisch geschützten ,
Stahlrohrleitungen, die sich ändernden Wechselspannungen ausgesetzt
sind – Ein neues Modell zum Verständnis der Wechselstromkorrosion**

C. Persson¹) & Å. Marbe¹) & R. Lundberg²) & G. Camitz³)

1) CarlBro, Dep. Elkaft, SE-205 09 MALMÖ,

Sweden

2) ES Mätteknik AB, PO Box 50 529, SE-202 50 MALMÖ,

Sweden

3) Swedish Corrosion Institute, Kräftriket-Building 23A, SE-104 05 STOCKHOLM,

Sweden

Abstract

During 2003 - 2004 a.c. corrosion has been studied on cathodically protected steel in soil exposed to varying a.c. voltage. The test site is located in the southern part of Sweden. Previously three investigations with constant low, medium and high a.c. voltages have been carried out at the same test site. The varying a.c. voltage has been designed, so that it corresponds to the normal load variations in a high voltage power grid. Thus, the test involves 8 h with high load (30 V) and 16 h with low load (5 V). Test coupons of two different areas (1 and 5 cm²) have been used, placed in clay and in sand respectively. Uniform corrosion and maximum local corrosion have been measured on each coupon after the ending of the exposure. Consequently, test coupons exposed for a.c. corrosion during very well controlled conditions give a possibility to compare how the corrosion rate is correlated with measurable parameters such as a.c. voltage level, a.c. current density, coupon area, type of soil (sand or clay). It is also possible to study the ratio between a.c. current density and d.c. current density.

This article presents the corrosion results of varying a.c. voltage. There is a clear tendency that the corrosion rate increases with increased a.c. voltage and increased a.c. current density, despite the high level of a.c. voltage occurs during short periods during the day. However, the differences in observed corrosion are large, and there seem to be important parameters, which are not under full control. Therefore, in order to achieve a better understanding of the different parameters that affect a.c. corrosion an electrical model has been developed. The electrical model can briefly be described as a rechargeable battery with different re- and discharge circuits. In the model the different chemical processes can be described as different electrical component series.

Hopefully this article can trigger similar model evaluations regarding a.c. corrosion correlation based on other tests and studies carried out elsewhere in Europe. Of special interest is a comparison of these results with other studies in hope of gaining more experience in the chemical process of a.c. corrosion.

Introduction and background

The influence from ac-current is a problem for cathodic protected pipelines. The ac voltage level causes the protection from the cathodic protection to decrease or totally disappear. Influence from ac-current on pipelines therefore gives ac-corrosion, even if they have cathodic protection.

Measurements and investigations of ac-corrosion on cathodic protected pipelines have been done at a test station in the south of Sweden. The same test station has been used in four different test series. The three previous ones have been presented at earlier CEOCOR congresses: in Brussels in 2000 and in Sicily in 2003. This paper shows the results from the latest (fourth) test series and compares them with the results from the three other test series. The test series 5/30V_{AC} was chosen to simulate the electric situation a pipeline exposed to when it is influenced by a high voltage ac-voltage power line. Normally, the effect in electrical power lines differs over day and night, therefore the test series was exposed to 5 V_{AC} in 16 h and 30 V_{AC} during an 8 hour period. The total test period was 1,8 years.

The paper also gives a theoretical information on the ac-corrosion mechanism named "battery model".

Experimental procedure

The investigation was carried out in a field test installation in which cathodically protected steel coupons buried in soil were exposed to constant AC-voltages. In the first three test series the voltage level was constant in all 24 hours, at levels 5, 10 and 30 V_{AC}. The fourth test series had 8 coupons exposed to 16 h with 5 V_{AC} and 8 h with 30 V_{AC}. The coupons realistically simulated a steel surface in a coating damage on a cathodically protected steel pipeline, which was exposed to an electrical influence for a long time from a high-voltage source with a 50 Hz alternating voltage.

The field-test installation and the test coupons

The field test installation includes a 150 meter long PE-coated steel pipe buried to a depth of 1.5 m. See **figure 1**. The original soil at the site consists of clay. Close to each end of the pipe, a large and deep pit was dug in the clay soil, which was then filled with sand. The groundwater level varies with the season but lies roughly at the pipe depth or higher for most of the year.

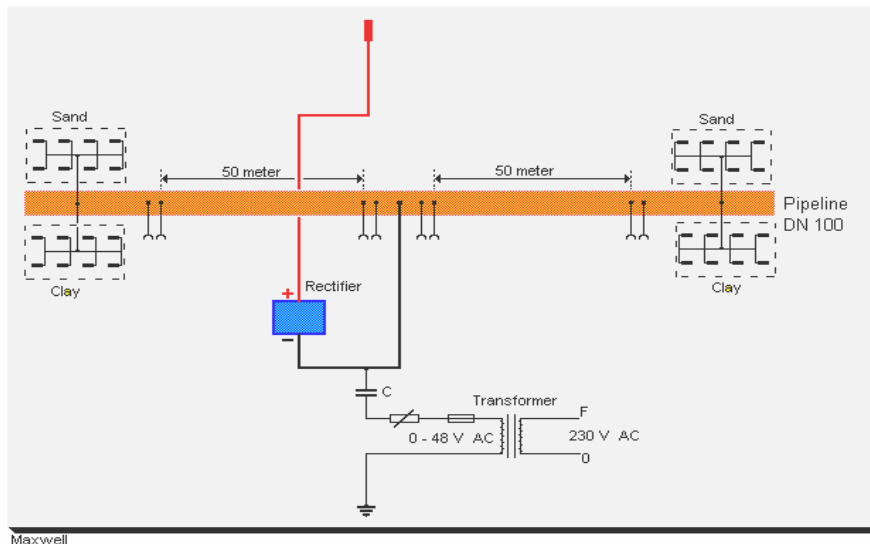

Figure 1. The field test plant with its electrical installations and buried test coupons.

At each end of the pipe coupons were buried at a depth of approximately 1m and were each electrically connected to the steel pipe via a cable. Half of the coupons were buried in clay and half in sand. Before the coupons were buried, they were carefully weighed and then covered with PE-tape. On one side of each coupon, a circular hole was cut in the tape so that a circular steel surface with a given area (1 cm² and 5 cm²) was exposed. For each area two coupons were exposed in clay and two coupons in sand. Some reference coupons were also installed.

During the exposure periods, a number of electrical parameters were measured on each coupon at intervals of about one month. The parameters measured were: The protection potential of the coupons with and without ohmic voltage drop (E_{on} and E_{off}), alternating voltage (U_{ac}), cathodic protection current (I_{dc}), alternating current (I_{ac}) and grounding resistance (R_{gr}) of all coupons. In this report the grounding resistance in the tables is given in kohm and is measured with a resistance instrument with a test voltage/current of 108 Hz. The alternating current (I_{ac}) which was recalculated into alternating current density (J_{ac}) and the

direct current, i.e. the cathodic protection current (I_{dc}), which was then recalculated into protection current density (J_{dc}) were also measured.

The exposure time for the test series was approximately 1,8 years. After exposure the coupons were visual analysed, photographed and fixed in an acid bath (Clarks solution) after which they were control weighed.

Corrosion rates

The corrosion rates, expressed as uniform corrosion and maximum local corrosion, on all coupons in the 5/30 V_{AC} and 30 V_{AC} -test series are shown in **table 1**.

Table 1: The corrosion rates (uniform corrosion and maximum local corrosion) and appearances after fixed the test coupons in the 5/30 V_{AC} and 30 V_{AC} .

Coupon	AC (V)	Surface (cm ²)	Soil	Corrosion rate				Appearance after pickle (cleaning)
				Uniform corrosion			Max.	
				(g/m ²)	(g/m ² år)	(µm/år)	(µm/år)	
356	5/30	1,1	sand	734	412	(53) [*]	23	Blasted
362	5/30	1,1	sand	533	299	38	47	Blasted
357	5/30	1,1	clay	307	173	22	92	Blasted, nail stick
363	5/30	1,1	clay	151	85	11	33	Blasted, varios depth
352	5/30	4,9	sand	119	67	9	34	Very light blasted
370	5/30	4,9	sand	143	80	10	15	Very light blasted
353	5/30	4,9	clay	85	48	6	20	Very light blasted
371	5/30	4,9	clay	73	41	5	18	Very light blasted
354	30	1,1	sand	367	206	26	280	Blasted, craters
364	30	1,1	sand	428	241	31	85	Light blasted, two craters
355	30	1,1	clay	340	191	25	55	Blasted, nail stick
365	30	1,1	clay	860	483	62	129	Pitting
350	30	4,9	sand	54	30	4	158	Partly blasted
372	30	4,9	sand	70	39	5	204	Chamfer
351	30	4,9	clay	163	91	12	154	Varios blasted
373	30	4,9	clay	229	129	17	245	Varios blasted

(53)^{*} pittings under PE coating

The corrosion rates for the test series 5/30 V_{AC} and for the test series with constant a.c. voltages 5 V_{AC} and 30 V_{AC} are shown in histograms in **figure 2**.

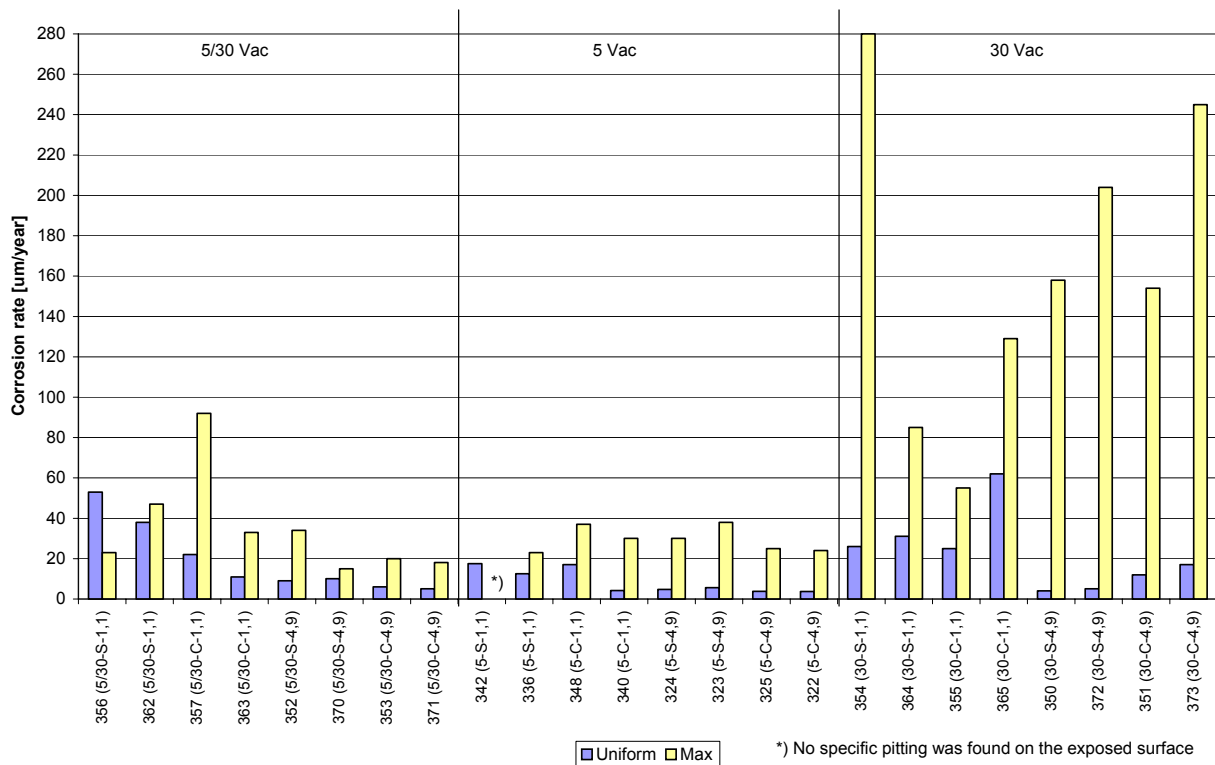

Figure 2: Uniform and maximum local corrosion rates on the test coupons in the 5/30 V_{AC}, 5 V_{AC} and 30 V_{AC} test series.

As seen in figure 2 the coupons exposed for varied a.c. voltages (5/30 V_{AC}), both the uniform and maximum local corrosion rate, are higher than if the coupons are exposed to 5 V_{AC} but lower than the 30 V_{AC} test series. The coupon no 357 in the 5/30 V_{AC} series has a high local corrosion rate compared to the coupons in the same series. An interesting observation is the fact that the measured off-potential (average of monthly measures) is quite positive and the protection is not satisfactory. **Figure 2** also shows that there seems to be a tendency of increasing local corrosion the higher the AC-voltage is.

The range of distribution of the corrosion rates in the series is shown in **table 2**.

Table 2: The range of distribution of the corrosion rates in the test series.

Type of corrosion	Distribution range of corrosion rates in test series		
	5 Vac	30 Vac	5 / 30 Vac
Average corrosion, µm/year	3 – 26	4 – 62	5 - 38
Localized corrosion, µm/year	11 – 51	55 - 280	15 - 92

As can be seen both in **figure 2** and **table 2** the corrosion rates vary widely between the test coupons in the test series. The uniform corrosion is higher in the 30 V_{AC} test series. This

relationship is the same for the local corrosion rates in the test series. In the 30 V_{AC} -test series some extremely high local corrosion rates were measured. Four coupons showed a local corrosion rate between 120 and 285 µm/year.

During this and earlier test series it was observed that the resistance between steel surface and earth increased over time and also varied in a large interval that not exclusively could be explained by soil humidity, see **Figure 3**. Generally the changes were larger for the coupons in clay (L).

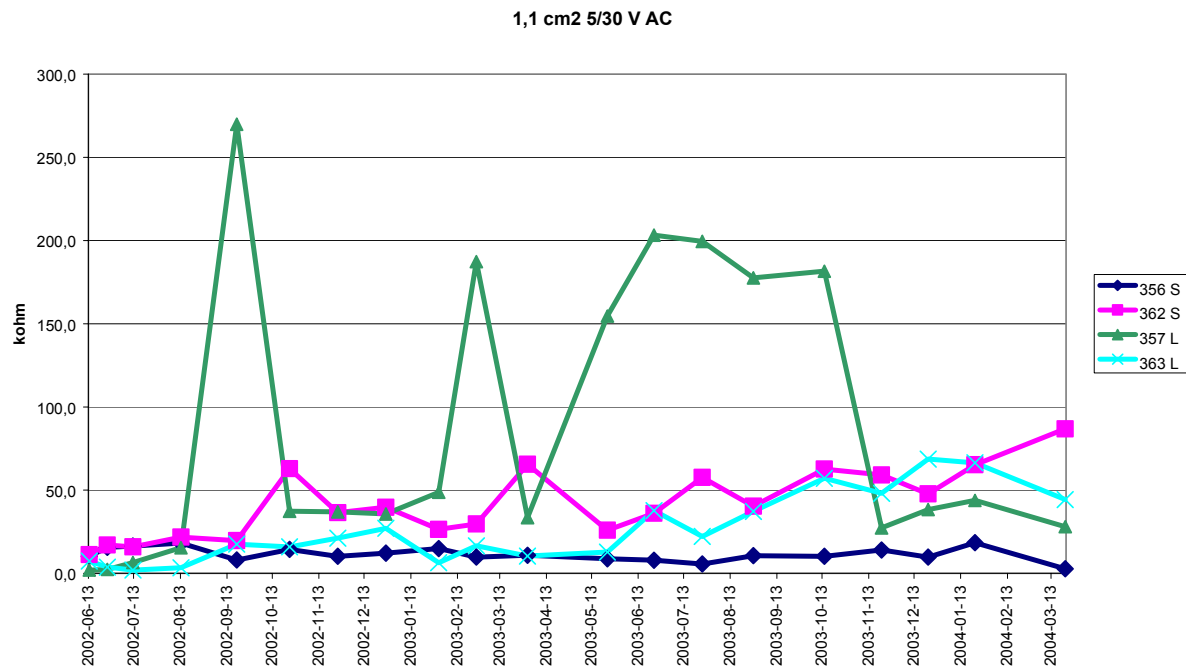

Figure 3: The resistance between steel surface and earth for four coupons (1,1 cm²) in sand (S) and clay (L).

Electrical model

In an effort to understand the variations in resistivity as discussed above and the different factors that affect ac-corrosion, an electrical model has been developed. The cathodic protection current can cause a lime layer on the steel surface depending on the soil type. The layer works like a layer capacitor where the close earth is one of the plates and the steel is the other plate. **Figure 4** shows an outline over a coating damage of a PE-coated pipeline and the electrical parameters between the steel surface and the surrounding earth.

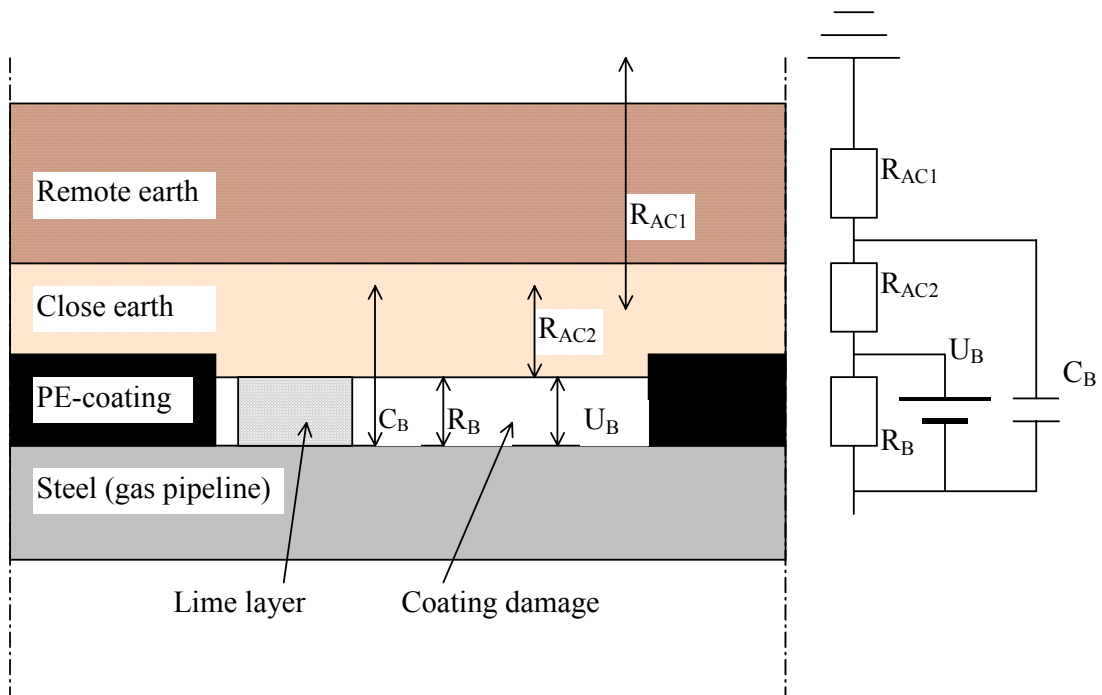

Figure 4: Physical and electrical description of a coating damage

The electrical model can briefly be described as a rechargeable battery, therefore the working name “Battery model” is used. The battery has different re- and discharge circuits. The steel areas at the coupons are possible to polarize to a dc-voltage potential, which is more negative than the natural corrosion potential (around $-0,6 V_{DC}$) for a steel surface in soil. This can be compared with a bad rechargeable battery, which can increase battery voltage under charging. Furthermore, a discharge process takes place when the cathodic protection is turned off, which means “the charge current “ to the battery /free steel surface disappears. In the area around the steel which is in contact with soil, it is the electrolyte that gives the chemical and electrical course. There are several different parameters in soil that influence pH-value in the electrolyte. At the end of this test series a pH-value of approx. 10 was measured on the exposed steel surface.. The test result gives at hand that during seasons with low humidity in the ground cathodic protection is able to build up a protection of lime layer that also protect against high a.c. voltages for short periods.

In **Figure 5** the Battery model is shown. The picture is completed with electrical parameters from one of the monthly measurements and oscilloscope data from the same time. In this case there was no phase angel between ac-current and voltage. Therefore there is no capacitor C_B . R_{AC} becomes a simple resistance for coupon 372 S. As can be seen in the figure, it is a good correspondence for E_{OFF} , which is also shown in the calculations.

Modeltest 372 Sand (4,9 cm²)

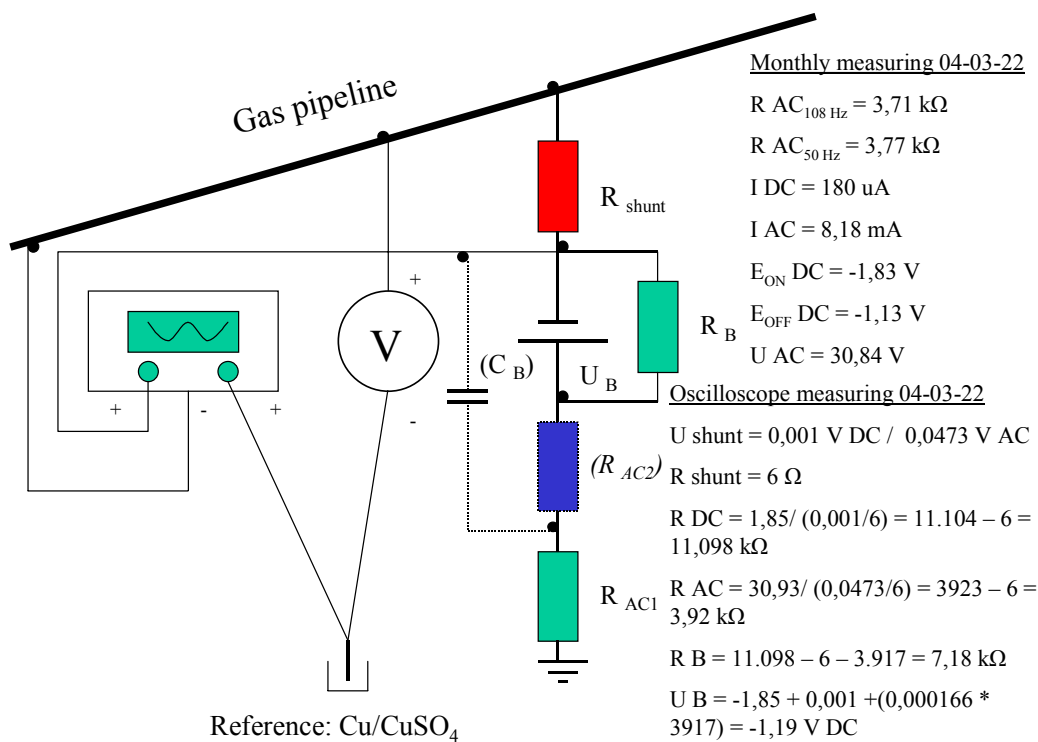

Figure 5: The Battery model

The layer capacitor causes a phase angle between the a.c. current and voltages. To determine the phase angle and thereby the size of the capacitor an oscilloscope was used. One of the coupons (no. 363) was recorded with the oscilloscope, see **Figure 6**. The phase angle was between 0.5 – 1.5 ms (9 – 27 degrees), which corresponds to some 1/10 μF . An interesting observation is that this coupon has high local corrosion. At the time for measurement the resistance between the steel surface and the surrounding earth was high, namely 44.3 kohm.

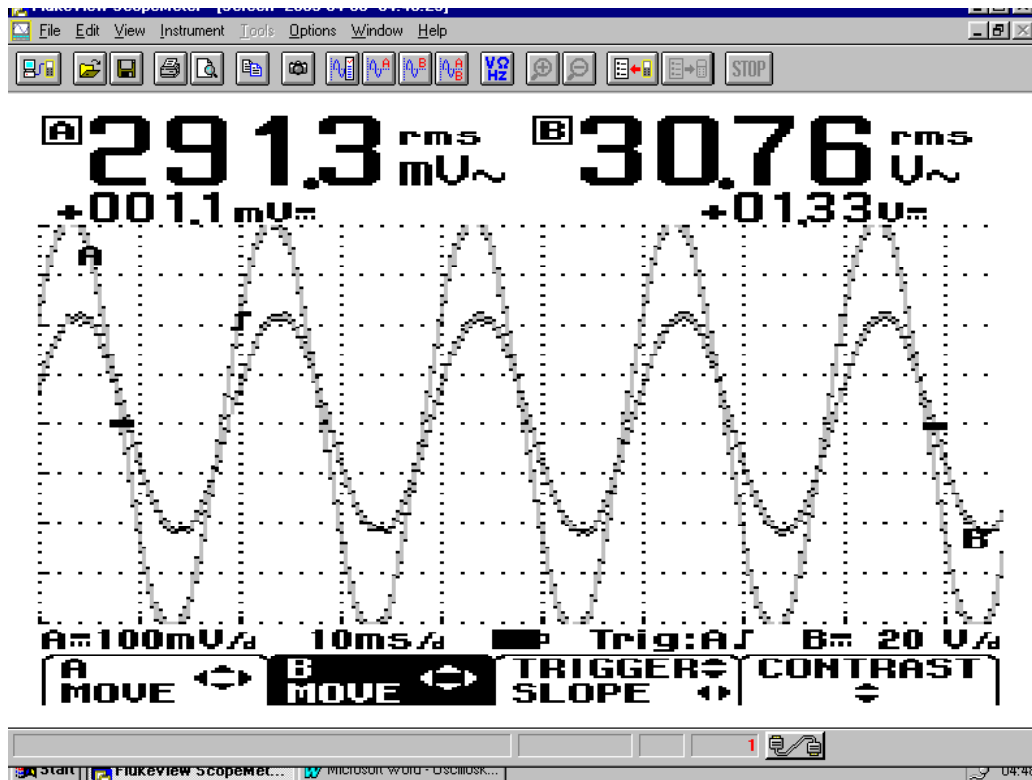

Figure 6: The phase angle of coupon no. 363.

There is a theory that the size of the layer capacitor indicates the risk of a.c. corrosion.

Results and Conclusions

All the test coupons have corrosion pitting in spite the fact that the cathodic protection was at a correct level. For the test coupons in the series with $5/30 V_{AC}$ the uniform corrosion rate was $5 - 38 \mu\text{m}/\text{year}$ and the maximum local corrosion rate was $15 - 92 \mu\text{m}/\text{year}$.

In the European standard EN 12954 (5) it is stated that a criterion for complete cathodic protection is a corrosion rate lower than $0,01 \text{ mm}/\text{year}$ ($10 \mu\text{m}/\text{year}$). Earlier test series have shown that nearly all coupons exposed for a.c. voltages below $5 V_{AC}$ meet this criterion. For the test series with various a.c. voltages $5/30 V_{AC}$ the coupons with small exposed steel surface do not meet the criteria, while the coupons with large steel surface do. The coupons exposed to higher a.c. voltages have higher average corrosion rate than the criterion for cathodic protection.

Based on uniform corrosion rate there was a clear increased risk of a.c. corrosion on the coupons with small areas ($1,1 \text{ cm}^2$) when the a.c. voltages increased. For the coupons with big areas ($4,9 \text{ cm}^2$) there were no significant difference in the uniform corrosion rate for the coupons exposed to different a.c. voltages. The maximum local corrosion rate do not depend on the size of the steel surface. However, this is the limited factor for corrosion rate on buried pipelines.

A general opinion is that a.c. corrosion is especially dangerous for small coating damages. It seems to be so for the uniform corrosion rate but not for the maximum local corrosion rate. The depth of local pittings on the large coupons is at least as deep as for the small coupons. This could depend on the protected layer that is built up on the surface (the capacitor) and the

fact that the pitting is larger on the steel surface that is directly in contact with the electrolyte (the close surrounding earth).

After having studied the different measurements there was a discussion if it really is the true off-potential that is measured, when the cathodic protection current is interrupted. Maybe it is possible to use the Battery model to explain this question.

Outlook

The electric and electro-chemical processes very close to a cathodic protected steel surface are still not fully understood when the steel is exposed to alternating current voltages. However, there are different electrical theories which describe the mechanism. A very interesting question is if it is possible to estimate the risk of increased corrosion by measuring the phase angle in spite of a satisfactory cathodic protection level. Is there a correlation between pitting corrosion and phase angle?

Another issue which was raised during the test series with different ac voltages is if it is possible to decrease the increased corrosion rate caused by the ac voltages. Probably an increased cathodic protection level decrease the corrosion rate, but the question is how much can the protection level increase without risk for other consequences (e.g. H₂ formation) and damage.